

CoolFlow™ and SilverLine® technologies improve process life!

Patent-pending CoolFlow nozzles and patented SilverLine electrodes improve cut quality and life – so you can cut more metal with one set of consumables. Follow the instructions on our quick set up card. The more you cut the more you save!

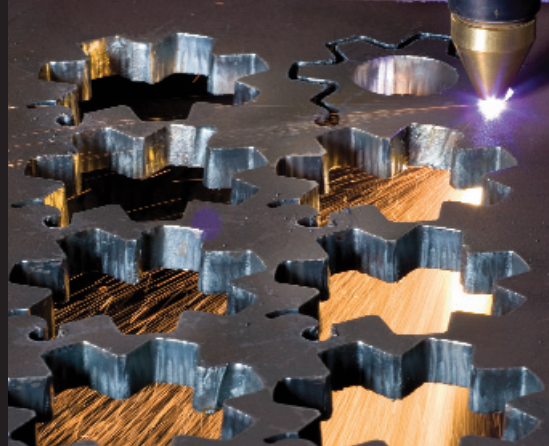

Centricut product for Kjellberg

PA-S70, PA-S75, FineFocus 800

Quick Set-up

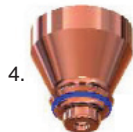

To achieve maximum CoolFlow nozzle life

With careful use, the CoolFlow nozzle can last 1:1 with the SilverLine electrode.

Properly tighten the nozzle cap: Make sure the nozzle cap is sealed tightly against the nozzle to maintain a proper seal and prevent leaking.

Pierce at correct height: Piercing too low causes molten metal (spatter) to hit the nozzle cap and nozzle. This is the most common cause of premature nozzle failure. Piercing too high can cause slow arc transfer and misfires.

Clean the nozzle and nozzle cap: Periodically clean the nozzle and nozzle cap to remove spatter. This will prevent double arcing.

Adjust arc voltage: As parts wear, adjust arc voltage up in 2-volt increments to keep the nozzle cap from dragging on the plate. Damage to the nozzle cap and nozzle occurs if the torch contacts the plate during cutting.

To achieve maximum SilverLine electrode life

A fully used SilverLine electrode will have a pit depth of 1.5 mm (.060").

Purge torch: After each parts change purge the torch for at least 30 seconds to remove residual moisture.

Leak check the torch after purging to make sure all o-ring and metal-to-metal seals are working as designed.

Adjust gas flows: Plasma gas flow rate is critical. High flow will cause rapid electrode wear and hard starting. Low flow will cause uncontrolled arcing. (See cutting tables in your owner's manual)

Adjust arc voltage: As the electrode wears, the torch will get closer to the plate. To compensate for this, increase arc voltage in 2-volt increments, up to 10 volts higher than the initial setting.

Avoid arc stretching: This can occur when rip cutting off the plate or when leading out to the dropped part. These "blowouts" shorten electrode life by 10 or more starts per occurrence.

Article number	Description	Centricut number	Air	Oxygen
1.	.11.828.921.300 SilverLine electrode, K2-XL	C53-1000		X
2.	.12.40870 Electrode, K2	C53-870	X	
3.	.12.40860 Gas guide cap	C53-860	X	X
4.	.11.828.901.420 CoolFlow nozzle, L1-XL, 160 Amp	C53-920	X	X
	.11.828.901.425 CoolFlow nozzle, L2-XL, 250 Amp	C53-925	X	X
	.11.828.901.427 CoolFlow nozzle, L4-XL, 300 Amp	C53-927	X	X
5.	.12.37790 Nozzle cap	C53-790	X	X

CoolFlow technology



CoolFlow nozzles are designed to optimize cut quality and speed

CoolFlow nozzles are designed to optimize cut quality and speed while providing long service life. State-of-the art computer modeling is used to analyze cooling water flow and heat transfer to optimize the design. CoolFlow nozzles are tested extensively in the lab and field and produced to exacting quality standards.

Key features of this nozzle design include:

1. Deep groove curved flow path – designed to provide coolant flow to the hottest area of the nozzle, eliminating stagnation and maximizing convection cooling.
2. Angled o-ring seal – more leak proof than conventional metal-to-metal seals and positioned away from the nozzle hot zone to eliminate failures.
3. Shoulder contact – reliably positions nozzle cap and provides conduction cooling of the nozzle.

Centricut CoolFlow nozzle

OEM nozzle

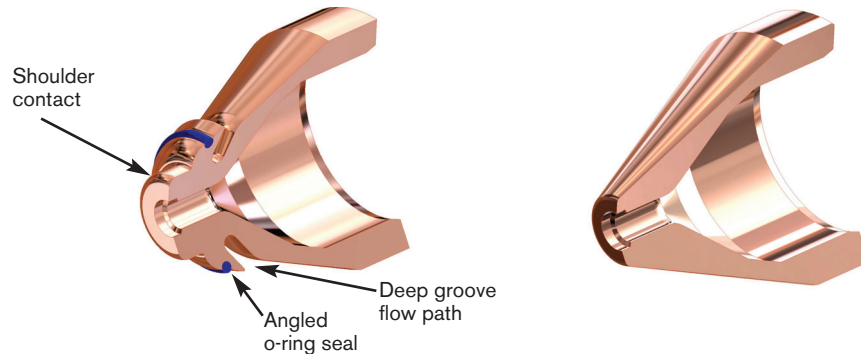

SilverLine technology

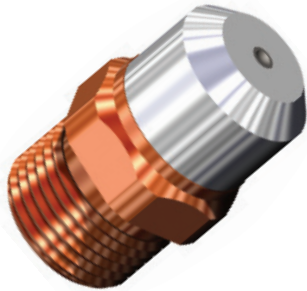

SilverLine technology involves fusing a silver front-end onto a copper electrode base. Inserting the hafnium emitter into an all-silver front end versus copper creates several advantages.

1. The hafnium-silver bond is stronger, allowing a deeper pit depth in the hafnium as the electrode is used.
 2. By diffusing more heat during use, silver slows the rate of hafnium wear.
 3. Cost/performance is optimized since silver is only used where it provides a benefit.
- All of these benefits combine to prolong electrode life and lower the cost of cutting.

Half-used electrode

This SilverLine electrode is only half consumed. The pit in the center of the part measures .75 mm (.030"). Electrodes are often removed prematurely due to cut quality deterioration related to nozzle failure. Additional life can be achieved by replacing the nozzle and leaving the electrode in place.

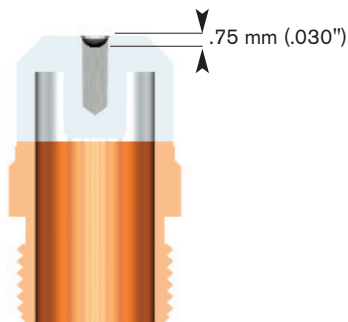

Fully-used electrode

This SilverLine electrode has provided full use. The pit depth is 1.5 mm (.060"). The operator increased the arc voltage by 10 volts from the first cuts made with this electrode to the last. This maintains a constant distance between the torch and the work-piece through the life of the electrode.

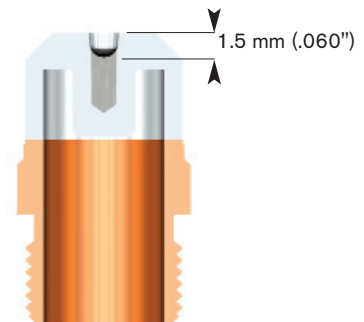

Contact your Hypertherm distributor or call 1-800-752-7623 for the location nearest to you.

Hypertherm®

Hypertherm, Inc.
Hanover, NH 03755 USA
603-643-3441 Tel

Hypertherm (S) Pte Ltd.
Singapore 349567
65 6 841 2489 Tel

Hypertherm (Shanghai) Trading Co., Ltd.
PR China 200052
86-21 5258 3330 /1 Tel

Hypertherm Europe B.V.
4704 SE Roosendaal, Nederland
31 165 596907 Tel

HYPERTHERM BRASIL LTDA.
Guarulhos, SP - Brasil
55 11 6409 2636 Tel

www.hypertherm.com

Centricut, Hypertherm, CoolFlow and SilverLine are trademarks of Hypertherm, Inc., and may be registered in the United States and/or other countries. All other trademarks are the property of their respective owners. Hypertherm is in no way affiliated with Kjellberg.