

Hypertherm®



***Centricut CO₂ laser consumables
for Murata Wiedemann® – Fanuc®***

Chemical code key

Lens

PFL	Pre-focus
MEN	Meniscus
PLX	Plano-convex
MTD	Mounted
Not MTD	Not mounted
MP5	Low absorption

Mirrors

SI	Silicon
GE	Germanium
ZNSE	Zinc-selenide
PS	Phase shift
MMR	Maximum metal reflector
ATFR	Absorbing thin film reflector
TRZ	Total Reflector – zero phase shift
ZPS	Zero phase shift
OC	Output coupler
RM	Rear mirror
COL-I	Collimator input
COL-O	Collimator output
AO	Adaptive optic
UC	Uncoated
MCX	Convex
MCC	Concave

Measurements

DIA	Diameter
FL	Focal length
ET	Edge thickness

Product is available for the following major OEM brands

Amada®

Behrens®

Bystronic®

Cincinnati®

Finn-Power®

GHT-SHT®

Haas®

Haco® – Technology Italiana®

Hankwang®

Laserdyne®

Laser Lab®

LVD®

Mazak®

Messer Griesheim®

Mitsubishi®

Murata Wiedemann® – Fanuc®

Niigata®

NTC® – Beyeler®

Precitec®

Prima Industrie®

Raskin®

Rouchaud®

Salvagnini®

Strippit®

Tanaka®

Thyssen®

Trumpf®

Technical service

OEM-trained technicians on staff with over 25 years of experience.

Free application support for all laser OEMs.

We stand behind our products with industry-leading technical expertise.

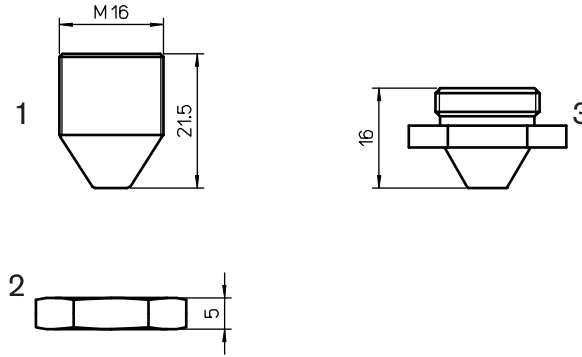

Consumables

Centricut part number	Reference number	Alternate reference	Description	Pkg qty
WI338-1210	P26-71270-60-1.0	L66	Nozzle – 1.0 mm	1
1 WI338-1214	P26-71270-60-1.4	L125	Nozzle – 1.4 mm	1
WI338-1215	P26-71270-60-1.5	L279	Nozzle – 1.5 mm	1
2 WI338-0001		AL46	Retainer nut	1
WI338-1110	P37-71110-039-1.0	L309	Nozzle – 1.0 mm	1
WI338-1112	P37-71110-039-1.2	L460	Nozzle – 1.2 mm	1
3 WI338-1115	P37-71110-039-1.5	L310	Nozzle – 1.5 mm	1
WI338-1120	P37-71110-039-2.0	L311	Nozzle – 2.0 mm	1
WI338-1125	P37-71110-039-2.5	L314	Nozzle – 2.5 mm	1

Optics

Centricut part number	Reference number	Type	Diameter	Focal length	Edge thickness
Lenses					
WI339-1014	658108	MEN	1.5"	5.0"	.310"
WI339-5160	304725	PLX	2.0"	5.0"	.315"

Optics care

Centricut part number	Reference number	Description	Pkg qty
TR300-6452	N/A	CO ₂ Lens paper (50 sheets)	1



Centricut and Hypertherm are trademarks of Hypertherm, Inc., and may be registered in the United States and/or other countries. All other trademarks are the property of their respective owners.

© 1/10 Hypertherm, Inc.

Hypertherm[®]

Hypertherm, Inc.
Hanover, NH 03755 USA
603-643-3441 Tel

Hypertherm Europe B.V.
4704 SE Roosendaal, Nederland
31 165 596907 Tel

Hypertherm (Shanghai)
Trading Co., Ltd.
PR China 200052
86-21 5258 3330 /1 Tel

Hypertherm (S) Pte Ltd.
Singapore 349567
65 6 841 2489 Tel

Hypertherm (India) Thermal Cutting
Pvt. Ltd.
Chennai, Tamil Nadu
91 0 44 2834 5361 Tel

Hypertherm Brasil Ltda.
Guarulhos, SP - Brasil
55 11 2409 2636 Tel

Hypertherm México, S.A. de C.V.
México, D.F.
52 55 5681 8109 Tel

www.hypertherm.com